

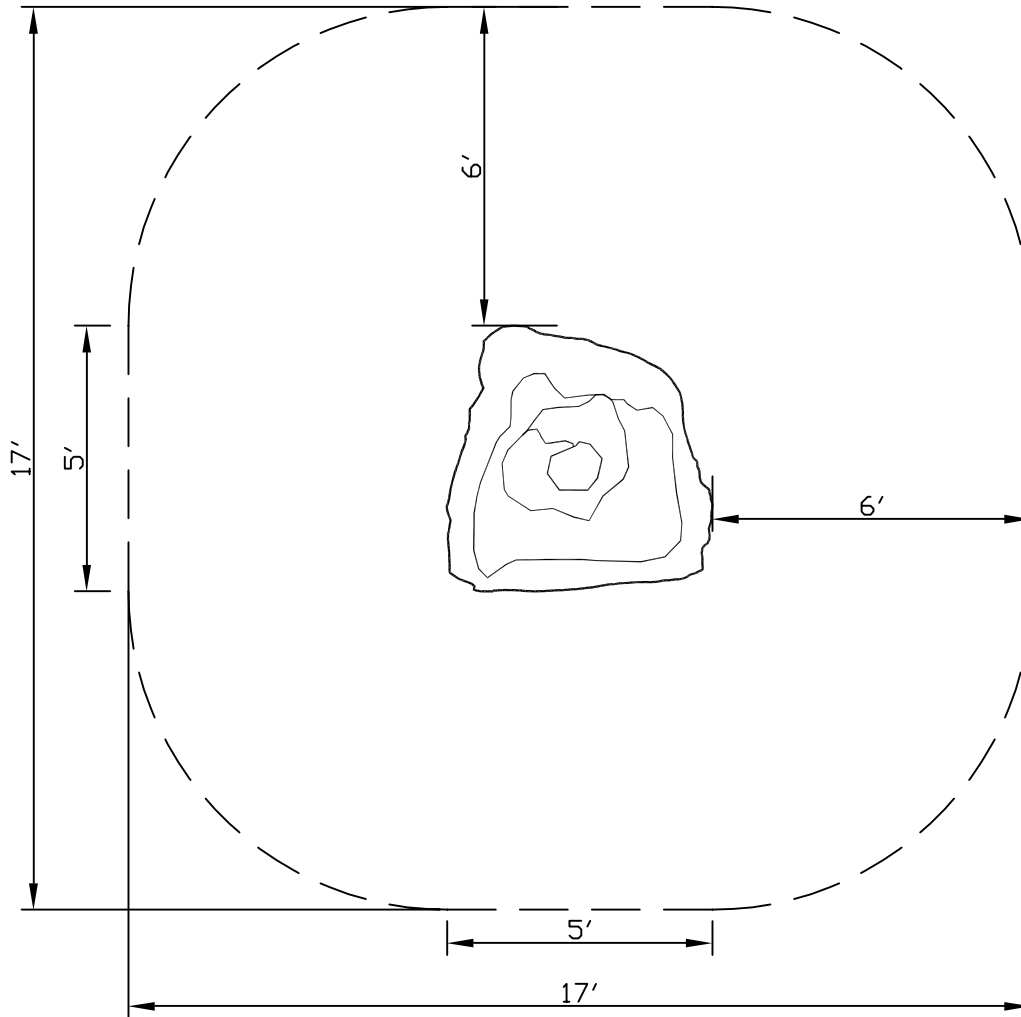

Park Pets & Boulders

park and play structures

Park Pets & Boulders
PO Box 32
Pismo Beach, CA 93448
Phone: 805-434-2305
Fax: 805-434-2369
www.parkpets.com



CASCADE #3

WT. 300 LBS.

TOP VIEW

MINIMUM AREA REQUIRED
17' X 17'

NOTES:

1. INSTALLATION TO BE COMPLETED IN ACCORDANCE WITH MANUFACTURER'S SPECIFICATIONS.
2. DO NOT SCALE DRAWINGS.
3. THIS PLAY AREA & EQUIPMENT IS DESIGNED FOR AGES 5 TO 12 YEARS.
4. ALL PARK PETS & BOULDERS MUST BE INSTALLED OVER RESILIENT "SAFETY" SURFACING APPROPRIATED TO THE SAFETY GUIDELINES OF YOUR CITY, COUNTY, STATE, OR COUNTRY.

Boulders
CASCADE#3



To verify product certification, visit www.ipema.org

To verify product certification, visit www.ipema.org